

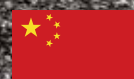

The agile all-rounders

# SERIES HD COMPACTLINE

HD 18 - HD 50





# THE WASP-WAIST ROLLERS

Compact compaction equipment for asphalt construction and earthworks

Founded in 1878, HAMM has focused on the manufacture of rollers for road building since the beginning of the 20th century. From that time on, HAMM has been the driving force and trendsetter in the industry. Many technologies and solutions that have become the standard in the compaction sector were developed by HAMM.

The articulated compact rollers in the HD CompactLine, with operating weights between 1.5 and 4.5 t, are real all-rounders for asphalt construction, earthworks and landscape gardening. They compact crushed rock, gravel or sand to exactly the same high quality as carriageways made from standard and special asphalts.

With their extremely compact shape, they also compact efficiently in narrow spaces. For example, in urban areas or on narrow paths. The low height also allows for compaction in halls, in parking decks and anywhere where the ceiling height is restricted. Thanks to their excellent gradeability, the rollers in the HD CompactLine also master challenging tasks such as compaction on steep ramps with ease.

With over 40 models – including vibration, oscillation and combination rollers – and drum widths between 0.80 m and 1.38 m, the HD CompactLine covers the entire range of compact rollers. In addition, there are numerous options such as chip spreaders or a cabin for the larger models, as well as solutions for special applications and local requirements.



## HAMM PRODUCT RANGE

**TANDEM ROLLERS**  
 > Drum width: 800 – 2.140 mm  
 > Operating weight: 1.5 – 14 t

**SOIL COMPACTORS**  
 > Drum width: 2.140 mm  
 > Operating weight: 20 – 26 t

**PNEUMATIC-TYRE ROLLERS**  
 > Width over tyres: 1.127 – 1.830 mm  
 > Operating weight: 4 – 27 t



# OVERVIEW OF THE HIGHLIGHTS

Perfectly equipped

## 01 Operation and comfort

- > Language-neutral, simple operation
- > Ergonomically optimal working conditions
- > Great freedom of movement for all drivers
- > Great driving and handling characteristics

## 02 Visibility

- > Perfect view of the drum edges, the area around the machine and the construction site
- > Great illumination in the dark

## 03 Compaction

- > The 3-point articulation and large drum diameter allow for homogeneous compaction
- > Great compaction power thanks to the high linear load
- > Even small areas can be compacted to a high standard of quality

## 04 Water sprinkling system

- > Reliable water system for constant sprinkling
- > Easy to fill and drain

## 05 Transport and safety

- > Rapid loading and unloading via a central lifting point
- > Safe transport thanks to numerous tie-down points

## 06 Maintenance and service

- > Extremely simple and fast maintenance
- > Large filler neck
- > Easily accessible maintenance points, wide-opening engine hood



- > Perfect rental machines
- > Environmentally friendly operation
- > Outstanding design



HAMM SUSTAINABILITY describes innovative technologies and solutions which are consistent with the sustainability objectives of the WIRTGEN GROUP.



# MAXIMUM COMFORT

Optimal working conditions for first-class compaction

## Comfortable driver's seat

easy to move

## Storage compartment on the operator's platform

for documents and personal items

## 12 V socket

as standard

## Armrests on both sides

for comfortable work and safe access



The operator's platform offers a lot of room – even for long legs.

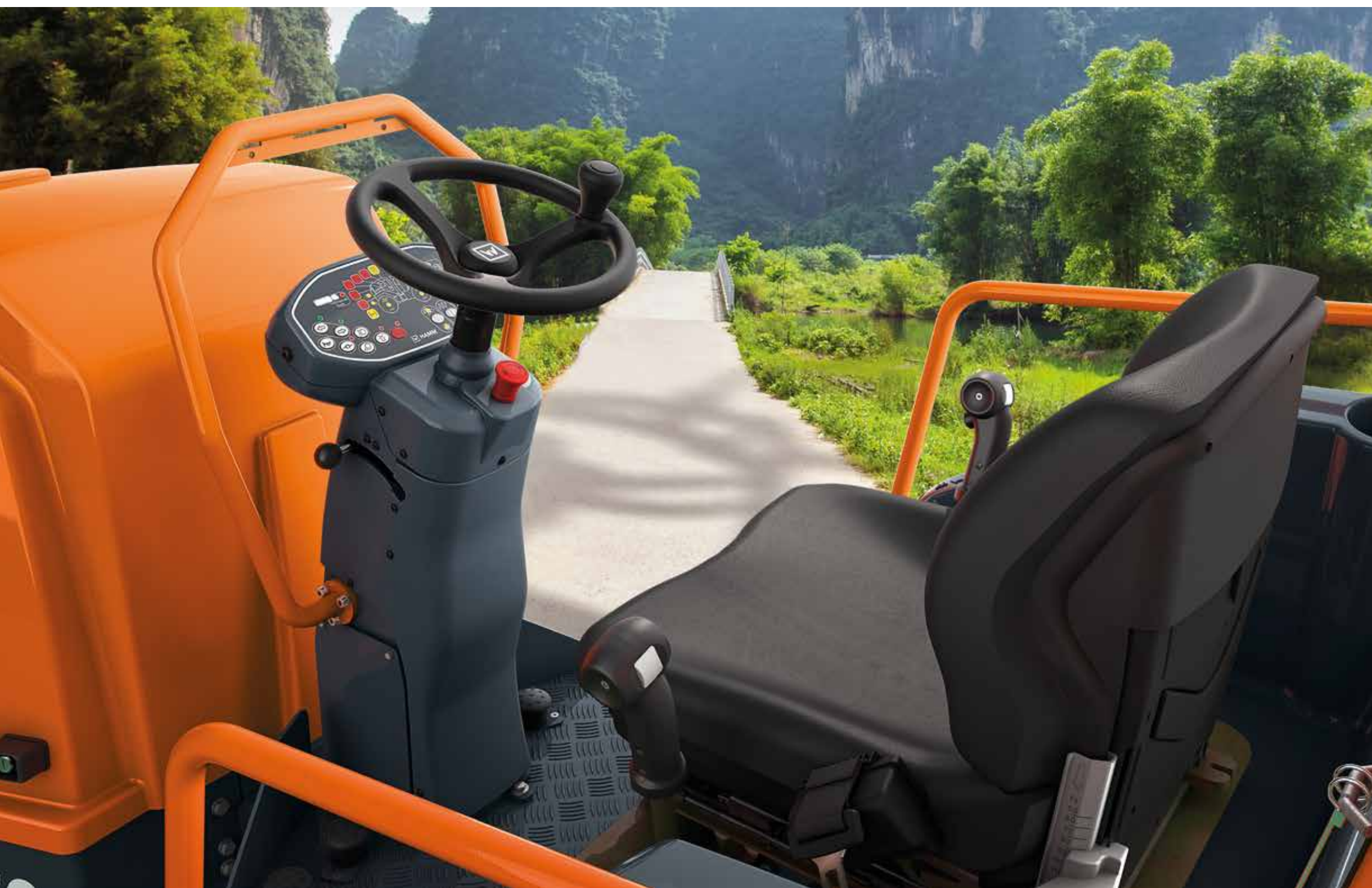

### Rollers with feel-good factor

The rollers in the HD CompactLine offer the drivers a comfortable seating position with great freedom of movement. The seat can be adjusted lengthways and can also be moved sideways on the larger models. Furthermore, there is also space for the arms, even if the driver's seat is moved all the way to the side.

### Comfortable workstation

The driver's seat, steering column, armrest, control lever and footplate are mechanically isolated from the frame. Great news for the driver, since this means that barely any vibrations are transmitted. This makes working on HD CompactLine rollers comfortable, even during long operating intervals. In combination with the 3-point articulation, which provides effective shock absorption, the rollers in the HD CompactLine offer first-class driving comfort.



# CLEAR AND SIMPLE

Clear and structured, and easy for everyone to understand

## Operation: Straightforward and intuitive

Operation of HD CompactLine rollers is extremely easy and can be mastered in a matter of minutes. Accurate labelling, straightforward symbols and colours clearly display the functions of the operating elements. It is therefore immediately clear, even to new personnel, how to operate the rollers. No language knowledge is necessary, meaning that the drivers can very quickly carry out compaction tasks to a high level of quality.

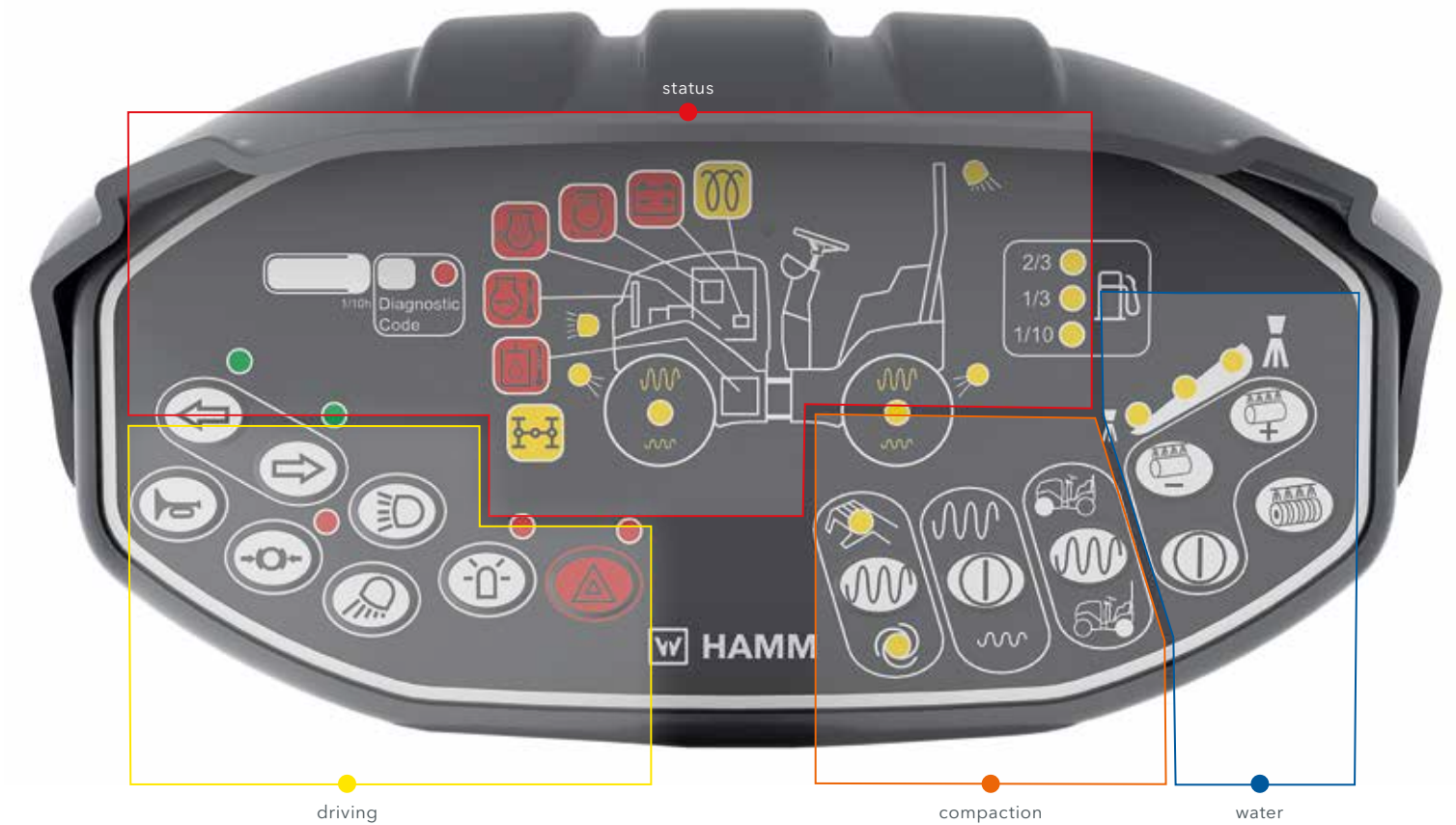

### 01 Dashboard

> Clear with language-neutral operation.

### 02 Vandalism protection

> Robust, lockable cover above the dashboard effectively protects against vandalism.

### 03 Two driving levers

> Two driving levers for effortlessly operating the drive control on both sides.

### 04 Central lifting point

> 2-in-1: The central suspension point with handles also serves as central lifting point for loading and unloading (HD 18-HD 35)

### 05 ROPS

> With folding mechanism for maximum flexibility during transport





# EVERYTHING IN VIEW AT ALL TIMES

Drum edges and construction site under control



## Great visibility, even at night

The rollers in the HD CompactLine can be equipped with working spotlights on the ROPS bracket. The durable, extremely bright LED lights guarantee great visibility on construction sites at night or in tunnels.

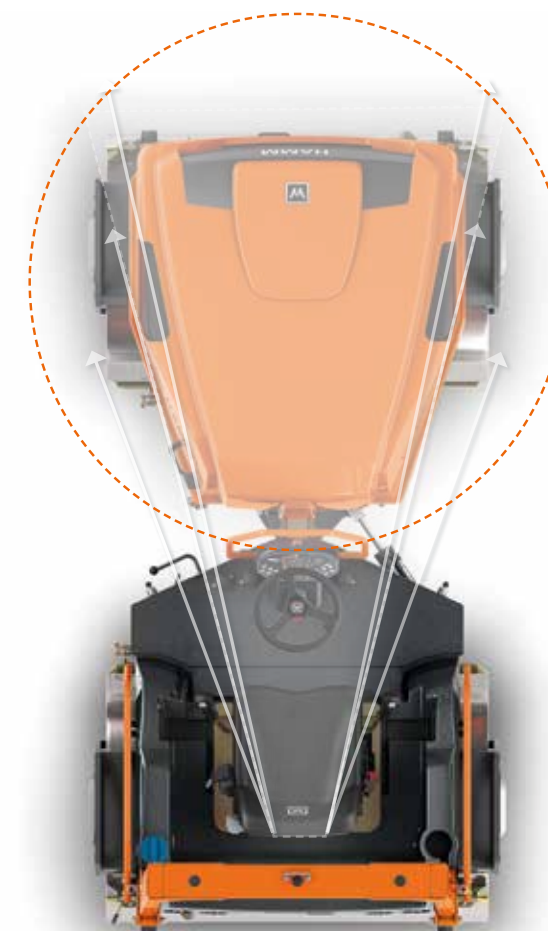

Clear view of the drum edges - thanks to the wasp waist!

## Wasp waist for great visibility

One distinguishing feature of the HD CompactLine series is its wasp waist. It guarantees an unobstructed view of the drum edges, as well as the surroundings in front of and beside the machine. This perfect visibility results from a clever design idea: Mounting the engine longitudinally. It allows for the conical shape of the engine hood with all of its advantages.

## Good side clearance as standard

All HD CompactLine rollers offer extremely good side clearance thanks to their inwardly offset suspensions. As a result, the rollers on the HD CompactLine can operate close to walls, kerb edges and other boundaries.

The models up to 2 t (HD 18/HD 20) have drums that are suspended on a single side. As an option, these rollers can be equipped with track offset or as an in-line version. The models with an operating weight greater than 2.5 t (HD 30-HD 50) are equipped with drums that are suspended on both sides and have a track offset of 50 mm.



# GREAT COMPACTION FORCE

Intelligent solutions in a compact design

## Large drums

Large drum diameters ensure high compaction quality because they actively prevent the formation of beads and dents. The success of the HD CompactLine is, in part, thanks to this, since its drums are considerably larger than the comparable rollers in this class. The HD CompactLine impresses accordingly with great work results.

## Leading when it comes to compaction force

The HD CompactLine also impresses when it comes to compaction power: For dynamic compaction with vibration, it achieves considerably higher centrifugal forces than other models in this market segment. In addition, all models have a high static linear load.



Elevated side plates provide plenty of side clearance when working alongside kerb edges.



## All compaction types are possible

The HD CompactLine is available with vibration and oscillation drums, and also as a combination roller with sets of wheels in the following versions:

### > Tandem rollers with two vibrating roller drums (VV)

Both drums can vibrate separately. Furthermore, on some models, the speed and, therefore, the vibration frequency can be changed at the touch of a button.

### > Tandem roller with one vibrating roller drum and one oscillation drum (VO)

HAMM is the only manufacturer in the world to offer oscillation drums for the compact segment drums. As a result, this gentle, low-noise and efficient technology can also be used on small construction sites.

### > Combination rollers (VT)

The combination rollers are equipped with a vibration drum on the front axle and a set of wheels on the rear axle.



## Quality thanks to even weight distribution

The 3-point articulation provides a further practical advantage by distributing the weight evenly over the front and rear drums. Furthermore, this leads to outstanding directional stability, impressive stability when cornering, as well as a high level of safety against overturning. This also prevents deformation of the asphalt. The result: A high level of safety and very smooth asphalt surfaces, even in tight curves.

## HAMM > MANOEUVRABILITY RIGHT UP TO THE EDGE

All models in the HD CompactLine can compact right up to the edge. HAMM has developed various solutions, depending on the size.

### Clear Side for HD 18-HD 20



For the smallest and most lightweight models in the HD CompactLine series, the drums are suspended on a single side and, as standard, are offset laterally from each other. This means that no part of the machine extends beyond the working width. This allows for complete compaction right up to the edge. A steering lock, even directly at the edge, is possible at any time, making the roller manoeuvrable at all times.

### Track offset for HD 30 - HD 50

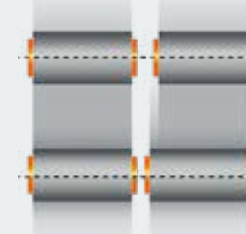

In the HD 30 - HD 50 models, a track offset by 50 mm to the right-hand side guarantees easy handling. In particular, the compaction up to the edge, right up to boundaries and obstacles, is therefore possible.



# IMPRESSIVE WATER MANAGEMENT

Well-conceived down to the last detail



## Always ready

A functioning water sprinkling system is essential for high-quality compaction. In the HD CompactLine, the water volume is set easily on the dashboard. A foot pedal can be used to activate an additional sprinkling boost.

To ensure that the nozzles on the spray bars are always ready for use, the water in the HD CompactLine is filtered three times: With a self-cleaning water filter on the fuel filler cap, a filter on the filler neck and separate filters upstream of the spray nozzles.

## Quick and easy checking and draining

Checking the filters and draining the tank quickly are among the most important tasks when it comes to the water system. HAMM has smart solutions for both.

The large, self-cleaning water filter can be checked in seconds because it is located directly behind the fuel filler cap. The central water tank outlet is located at the lowest point of the machine, beneath the driver's seat. This position allows for complete draining. One single manual operation is all it takes to completely drain the water tank in the rear vehicle.



For the edge pressing and cutting device, there is a separately activated sprinkling system. It can be activated by the driver via a switch.

## 3-fold filtering

For reliable water sprinkling

## Adjustable water volume

In three levels via a button on the dashboard

## Foot pedal

For fast additional sprinkling



# FROM A TO B WITH EASE

Transported quickly

## Rapid loading and unloading

HAMM has ensured simple loading of the rollers. As a result, the rollers in the HD CompactLine are ready for use in no time at all. Plenty of easily accessible tie-down points enable quick and secure fastening of the rollers to the transport vehicle. Unloading them on the construction site is also a breeze.



Special feature: The models with operating weights up to 3 t can be loaded and unloaded using the central lifting point on the stirrup. This also allows them to be lowered into narrow trenches or structures for compacting there.



## Numerous safety features

The rollers in the HD CompactLine series have many safety features. The drivers therefore intuitively find handholds wherever they need them as they enter the machine. When driving and compacting, the view of the construction site is always excellent, thanks to the machine design and lighting.

The seat belt for the driver is provided as standard.

For the safety of the machine and reliable operation, HAMM has also integrated a robust, lockable cap on the dashboard. It protects effectively against vandalism and damage that may prevent safe operation.

As an option, the rollers can also be equipped with a back-up alarm. It automatically warns the environment when the machine is driving backwards.

## Folding ROPS

The ROPS bracket offers the drivers a high level of safety. The bracket with easy-to-operate folding mechanism comes as standard. This makes the roller small for transport. This helps to promote maximum possible flexibility.





# COMFORTABLE CHECK

All service points on one side

## High-speed maintenance

Daily maintenance of the HD CompactLine rollers is not only simple but can also be completed very quickly. One reason for this is that all important maintenance points on the engine and hydraulic system are located on one side.

## Everything within easy reach

The maintenance points are clearly identifiable under the wide-opening engine hood, and are readily accessible without the need for tools. It is therefore extremely easy to check and replace the filters, and a large filler neck guarantees convenient refilling of the hydraulic oil. Furthermore, the central electrical system is located in the steering column. This also enables speedy servicing and very simple maintenance.



- 01 Engine hood**  
Opens wide, making checks effortless
- 02 Diesel tank**  
Large dimensions, easy to fill
- 03 Filters**  
Checking and replacing the engine filters and hydraulic oil filters is extremely easy
- 04 Water tank**  
Generously proportioned, easy to fill
- 05 Central electrical system**  
Easy access in the steering column



## Ideal for rental use

The intuitive operation of HD CompactLine rollers is also important in terms of safety and economic viability. It enables safe and productive compaction right from the start. Machine rental companies, too, appreciate this advantage because HD CompactLine rollers are not only small and productive, but also exceptionally easy to handle.



## Design

Since the 1980s, HAMM has considered design to be a crucial element in product development. And this has proven to be a successful move, as illustrated by the fact that HAMM has, to date, won close to 40 international design and innovation awards, making it the front runner in the construction industry.



## Environmental protection at every stage

On the construction site, HAMM rollers are impressive thanks to their low fuel consumption. What's more, most models can not only be operated with diesel, but also with non-fossil fuels. In addition, HAMM constantly strives to reduce emissions and the use of resources during production of rollers in the factories.





# OPTIONS FOR EVERY EVENTUALITY

Tailored for all applications and regions

**HAMM has thought of everything. Every road construction company will find the right equipment to meet its needs in the extensive list of options.**

## Protective roof

Protective roof made from glass-fibre-reinforced plastic on the ROPS bracket. Protects against weather conditions such as sun and rain.

## Edge pressing and cutting device

For all models of 2.5 t and above: Clearly visible. For clean delineation of the paths, can be expanded by track indicator. Suitable pressing rolls and cutting wheels available in many sizes and diameters.

## Folding scrapers

Cleans the drums. Can be folded up using a foot lever. Additional protective guards guide water out of the sprinkling system to the drum. HD 18 - HD 20 are available with or without track offset as an option, depending on the drums.

## Work lighting

Bright LED working spotlight on the ROPS or protective roof.

## Back-up alarm

Acoustic signal to warn people when driving backwards.



Edge pressing and cutting device with track indicator



Protective roof, mounted on tiltable ROPS

# YOUR WIRTGEN GROUP CUSTOMER SUPPORT

Service you can always rely on.

Place your trust in our reliable and fast support during the complete life cycle of your machine. Our wide service offer includes suitable solutions to meet all of your challenges.



## Service

We keep our service promises - with fast and uncomplicated assistance both on the building site and in our professional workshops. Our Service team has received expert training. Thanks to special tools, repair, care and maintenance work is completed quickly. Upon request, we can support you with tailored service agreements.

> [www.wirtgen-group.com/service](http://www.wirtgen-group.com/service)



## Training

Staff responsible for the WIRTGEN GROUP's product brands are specialists in their areas and have decades of application experience. Our customers also greatly benefit from these experts. In our WIRTGEN GROUP training courses, we gladly pass on our knowledge to operators and service personnel.

> [www.wirtgen-group.com/training](http://www.wirtgen-group.com/training)



## Spare parts

Original parts and accessories from WIRTGEN GROUP can ensure the high reliability and availability of your machines in the long term. Our experts will be glad to advise you on application-optimised wear part solutions. Our parts are available worldwide, at any time and are easy to order.

> [parts.wirtgen-group.com](http://parts.wirtgen-group.com)



## Telematics solutions

Construction machines with leading technology and perfected telematics solutions work hand-in-hand in the WIRTGEN GROUP. Intelligent monitoring systems such as WITOS or JD Link\* not only facilitate the maintenance planning of your machines but also increase productivity and economy.

> [www.wirtgen-group.com/telematics](http://www.wirtgen-group.com/telematics)

\* WITOS and JD Link are not currently available in all countries. Please consult your responsible branch or dealer if you have any questions in this area.



# OVERVIEW OF THE TECHNICAL DATA



## HD COMPACTLINE SERIES

Machine type	Basic data				Drums/variants		
	Weight class (t)	Drum width (mm)	Engine output (kW)	Max. working width (mm)	VV	VO	VT
<b>Machines in accordance with exhaust emission standard MEE4</b>							
HD 18	1,5	800	16,1	872	•		
HD 20	1,5	1000	16,1	1070	•		
HD 30	2,5	1000	24,4	1050	•		•
HD 35	3	1200	24,4	1250	•	•	•
HD 50	4,5	1380	36,5	1430	•	•	•

VV Vibration at front - vibration at rear  
 VO Vibration at front - oscillation at rear  
 VT Vibration at front - set of wheels at rear





# HAMM



### 维特根香港有限公司

#### Wirtgen Hong Kong Ltd.

Unit C, 20/F., Morrison Plaza,  
9 Morrison Hill Road,  
Wan Chai Hongkong

香港湾仔摩理臣山道9号  
天乐广场20楼C室

电话 : (852) 2526 0022  
传真 : (852) 2523 9047  
E-mail : marketing.hongkong@wirtgen-group.com

### 维特根(中国)机械有限公司

#### Wirtgen (China) Machinery Co., Ltd.

No. 395 Chuang Ye Road,  
Langfang Economic & Technical Development Zone,  
Langfang, Hebei Province 065001,  
P. R. China

中国河北省廊坊经济技术开发区创业路395号  
邮政编码 : 065001  
电话 : (0316) 225 0100  
传真 : (0316) 225 0190  
E-mail : marketing.china@wirtgen-group.com

### 维特根(中国)机械有限公司 上海办事处

#### Wirtgen (China) Machinery Co., Ltd. Shanghai Office

Room 405, North Building, Vanke Plaza,  
37 Shui Cheng Road South, Changning District,  
Shanghai 201103, P. R. China

中国上海市长宁区水城南路37号  
万科广场北楼405室  
邮政编码 : 201103  
电话 : (021) 6270 2568  
传真 : (021) 6270 2552  
E-mail : marketing-sh.china@wirtgen-group.com

### 佛山维特根机械有限公司

#### Wirtgen (Foshan) Machinery Co., Ltd

No. 41, Xile East Road, Leping Town,  
Sanshui District, Foshan,  
Guangdong Province 528137, P.R.China

中国广东省佛山市三水区乐平镇西乐大道东41号  
邮政编码 : 528137  
电话 : (0757) 8831 3700  
传真 : (0757) 8831 3701  
E-mail : marketing-fs.china@wirtgen-group.com

### 维特根(中国)机械有限公司 西安办事处

#### Wirtgen (China) Machinery Co., Ltd. Xi'an Office

B1103A, Chuang Ye Square, No. 48, Keji Road,  
Hi-tech Zone,  
Xi'an 710075, P. R. China

中国西安市高新区科技路48号创业广场B1103A  
邮政编码 : 710075  
电话 : (029) 8886 9175  
传真 : (029) 8886 9177  
E-mail : marketing-xa.china@wirtgen-group.com

### 太仓维特根机械有限公司

#### Wirtgen (Taicang) Machinery Co., Ltd.

No. 12 Xinmiao Road,  
Taicang Economy Development Area,  
Jiangsu Province, 215400 P.R. China

江苏省太仓市新苗路12号  
邮编 : 215400  
电话 : (0512) 8882 9600  
传真 : (0512) 8882 9690  
E-mail : marketing-tc.china@wirtgen-group.com

### 维特根(中国)机械有限公司 北京办事处

#### Wirtgen (China) Machinery Co., Ltd. Beijing Office

Room C306, First Shanghai Center,  
No. 39 Liangmaqiao Road, Chaoyang District,  
Beijing 100125, P. R. China

北京市朝阳区亮马桥路39号  
第一上海中心C306  
邮政编码 : 100125  
电话 : (010) 8456 4996  
传真 : (010) 8456 3036  
E-mail : marketing-bj.china@wirtgen-group.com

### 维特根(中国)机械有限公司 乌鲁木齐办事处

#### Wirtgen (China) Machinery Co., Ltd. Urumqi Office

Room B, 19/F, Tower of China Merchants Bank,  
No. 2 Huanghe Road,  
Urumqi 830000, P. R. China

中国新疆乌鲁木齐市  
黄河路2号招商银行大厦19楼B座  
邮政编码 : 830000  
电话 : (0991) 559 8766  
传真 : (0991) 559 8767  
E-mail : marketing-urumqi.china@wirtgen-group.com



了解更多信息, 请扫描二维码或者点击访问  
[www.wirtgen-group.com/products-hamm](http://www.wirtgen-group.com/products-hamm)