

Technical Information

MOBIREX MR 130(i) PRO



Track-mounted impact crusher

For use in natural stone and recycling

MOBIREX PRO

Series

HIGHLIGHTS

- > Generously dimensioned double-deck prescreen with 2.9 m² open screening surface
- > Fully hydraulic gap adjustment and overload system
- > Diesel-electric, connection to external power supply (optional)
- > Simple and intuitive SPECTIVE control concept
- > Powerful double-deck post screening unit, for use as a single-deck or double-deck screen

MOBIREX MR 130(i) PRO mobile impact crusher

The MOBIREX MR 130(i) PRO covers a very wide application range in natural stone and recycling. A positive feature of the plant is its all-electric drive concept with the option of an external power supply. CO₂-free operation guarantees low energy consumption per ton of final product.



TECHNICAL DATA MR 130(i) PRO	
Performance levels	
Feed capacity up to approx. (t/h)	600
Production output with rubble up to approx. (t/h)	450 ¹⁾
Production output with demolished concrete up to approx. (t/h)	400 ¹⁾
Production output with limestone up to approx. (t/h)	400 ¹⁾
Production output with milled asphalt up to approx. (t/h)	220 ²⁾
Feeding unit	
Max. feed size (mm)	1,040 x 650
Feed height (with extension) (mm)	4,350 (4,840)
Hopper volume (with extension) (m ³)	5 (9)
Width x length (with extension) (mm)	2,250 x 3,700 (3,000 x 3,700)
Vibrating feeder	
Width x Length (mm)	1,100 x 2,700
Pre-screening	
Type	Double-deck heavy-piece screen
Width x Length (mm)	1,210 x 2,400
Side discharge conveyor rigid (optional)	
Width x Length (mm)	650 x 6,600
Discharge height approx. (mm)	3,550
Side discharge conveyor can be folded hydraulically (optional)	
Width x Length (mm)	650 x 6,000
Discharge height approx. (mm)	3,400
Crusher	
Impact crusher type	SHB 130 - 090
Crusher inlet width x height (mm)	1,300 x 900
Crusher weight approx. (kg)	17,500
Rotor diameter (mm)	1,200
Crusher drive type, approx. (kW)	electric, 250
Adjustment of impact toggles	infinitely variable, fully hydraulic
Discharge chute	
Width x Length (mm)	1,435 x 2,670
Crusher discharge conveyor	
Width x Length (mm)	1,400 x 12,100
Discharge height approx. (mm)	4,400
Power supply unit	
Drive concept	diesel-electric
Drive output of Scania diesel engine (kW)	478
Generator (kVA)	550
Post screening unit (optional)	
Type	Double-deck screen
Width x length of upper deck approx. (mm)	1,550 x 5,500
Width x length of lower deck approx. (mm)	1,550 x 4,700
Side discharge conveyor, medium grain: Width x length approx. (mm)	650 x 6,800
Side discharge conveyor, medium grain: Discharge height approx. (mm)	3,400
Discharge height, fine grain conveyor approx. (mm)	4,000
Return conveyor: Width x length approx. (mm)	650 x 11,200
Transport dimensions without options	
Transport height approx. (mm)	3,900
Transport length approx. (mm)	20,965
Transport width approx. (mm)	3,455
Transport dimensions with post screening	
Transport length with screening unit approx. (mm)	23,275
Transport width with post screening unit approx. (mm)	3,500
Transport weight of screening unit approx. (kg)	13,000 ³⁾
Transport weight of basic plant approx. (kg)	64,000
Transport weight max. configuration approx. (kg)	83,500

OPERATING POSITION

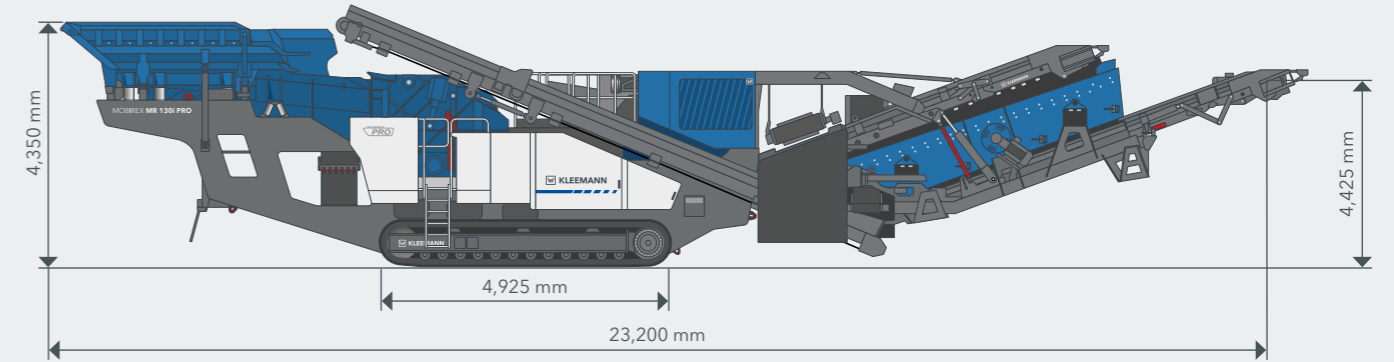

MATERIAL FLOW



The MOBIREX MR 130(i) PRO excels with outstanding product quality and very high product output. The Continuous Feed System (CFS) guarantees continuous crusher utilisation. Thanks to the fully hydraulic crusher gap adjustment, machine parameters can be adapted quickly to the application. The overload system ensures effective

protection for the crusher and high plant availability even with non-homogeneous feed material. Thanks to the optional double-deck post screening unit, splitting of the target grain size into two separate material flows is possible. Lightweight material can also be removed from both material flows by means of wind sifters.

¹⁾ for final grain size 0 - 45 mm with approx. 10 - 15 % oversize grain

²⁾ for final grain size 0 - 16 mm with approx. 10 - 15 % oversize grain

³⁾ double-deck post screening unit incl. two transfer conveyors and middle grain conveyor

STANDARD EQUIPMENT

- > Hydraulically-folding feed hopper, can be operated from ground
- > Frequency-controlled vibrating feeder
- > Frequency-controlled prescreen, stepless speed control
- > Continuous Feed System (CFS) for optimum crusher loading
- > Automatic crusher gap adjustment
- > Integrated overload protection
- > Rotor lock & turn device: system for securely turning and locking the rotor for maintenance tasks or clearing blockages
- > Swivel arm for changing rotor ledges
- > SPECTIVE control concept: menu-guided user interface, 12-inch control panel; telematics system for efficient fleet and service management
- > SPECTIVE remote control: wired and radio remote control incl. switch-off function for feeding unit
- > LED lighting
- > Water spray system for dust reduction

OPTIONS

- > Hopper extension: hydraulically folding
- > Hopper filling aids for rearward loading: width of feed opening 3,300 mm
- > Side discharge conveyor, rigid: can be fitted on the left and right, must be disassembled for transport
- > Foldable side discharge conveyor, hydraulically foldable, configurable on both sides, remains on machine for transport
- > Co-vibrating crusher bypass flap for flexible change-over between side discharge and crusher bypass
- > External power supply for efficient mains operation
- > Reversible fan for dedusting the engine compartment

OPTIONS

- > Raised engine air intake for reduced dust load
- > Power pack housing for damping noise sources, incl. sealing of the power pack base as noise and dust protection
- > Climate control packages: hot climate or cold climate package
- > Electromagnetic separator or permanent magnetic separator, suspended flexibly by chains, can be raised and lowered hydraulically
- > Reinforced conveyor belt for crusher discharge conveyor
- > Double-deck post screening unit, use as a single-deck or double-deck screen, production of up to two classified final grain sizes, incl. swivelling return conveyor
- > Return conveyor frequency converter for precise speed control
- > Middle grain conveyor, remains on the post screening unit for transport
- > Belt scale, available for crusher discharge conveyor, side discharge conveyor, middle grain conveyor and fine grain conveyor
- > Belt cover canvas, for rigid side discharge conveyor, crusher discharge conveyor and fine grain conveyor
- > Wind sifter for cleaning the oversize grain and medium grain to remove foreign and lightweight materials
- > SPECTIVE CONNECT for displaying all important machine information directly on the smartphone
- > Camera system for monitoring the feeding unit and the transfer point to the return conveyor from the ground, also available with radio extension, additional connection to SPECTIVE CONNECT
- > Small radio remote control with key operating functions
- > Quick Track for selecting machine operating mode quickly and easily, operation via radio remote control
- > Line coupling for interlinking with other KLEEMANN plants
- > Premium lighting

KLEEMANN GmbH

Manfred-Wörner-Str. 160
73037 Göppingen
Germany

T: +49 7161 206-0
F: +49 7161 206-100
M: info@kleemann.info

www.kleemann.info

